



First Aviation Services Inc.®



Actuators | Advanced Composite Repair | Batteries | Electro-Mechanical | Electronics | Engineering Services | Gearboxes & Motors | Hydraulics | Hydrostatic Services
Landing Gear | Lighting | Metal Bond | Propellers | Prop Governors | Regulators & Valves | Sheet Metal Structures | Stratoflex Hoses | Wheels & Brakes

COMPANY OVERVIEW & PRODUCT LINE



LETTER FROM OUR VP & GENERAL MANAGER

Dear Aerospace Colleagues,

For nearly 50 years, Aerospace Turbine Rotables, Inc. has been serving corporate, military, and general aviation operators with a continuously expanding portfolio of the highest quality component repair services. I want to share this brochure that summarizes some of our extensive product offerings with the hope that we can explore new business opportunities together.

AeTR's product offerings include landing gear overhaul for some of the most popular corporate and military aircraft including the **Phenom, Challenger, Global Express, Lear 45, Gulfstream, Pilatus PC-12, Beech T-6, and King Air**. Our safety equipment line includes crew oxygen masks as well as extensive lines of hydrostatic services. The structures group performs repairs on composite and sheet metal components while our actuators group has added flutter dampers to our expanding capabilities for civilian and military aircraft. Our Addison, TX facility services and repairs a broad range of Lead-Acid and Ni-Cad batteries as well as Emergency Power Supplies for the general aviation as well as business jet markets.

AeTR recognizes that the **people, processes, and ethical standards of an organization are key** to the quality of the MRO cycle. AeTR embodies the resources, values, and attributes of our organization into every component we process.

We utilize key performance indicators to aid in managing each article in accordance with quoted schedule and price, ensuring every task is performed with **proper discipline and diligence, while communicating effectively with our customers**. Our goal is to simplify your choice of MRO partner by providing an excellent cost-effective range of products.

As a proud member of the First Aviation Services family of companies, AeTR is complemented by our sister companies **Piedmont Propulsion Systems, LLC, Aviation Blade Services, Inc., Heliblade International, LLC** and **Evolution Aerospace, Inc.** which enjoy their own rich legacy, an exciting future, and the same unwavering commitment to customer satisfaction. Our parent company, **First Aviation Services Inc.** is committed to investing in the future of its companies and enabling the development of solutions which bring positive impact to this incredible industry.

Steven Jordan

Vice President & General Manager
Aerospace Turbine Rotables, Inc.

**EXPERIENCE
YOU CAN RELY ON**



First Aviation Services Inc.*

5 Company Overview /
First Aviation Services Inc.

AeTR PRODUCT LINES

- 8** Landing Gear
- 12** Hydraulics
- 14** Mechanical & Electro-Mechanical
- 16** Prestolite Power Packs
- 17** Hydrostatic & Safety Equipment
- 18** Oxygen Cylinders
- 19** Fire Bottles
- 20** Oxygen Masks & Regulators
- 22** Electronics
- 24** Structures
- 26** Engineering
- 28** Stratoflex Hoses
- 29** Program Management
- 30** FAA-PMA Parts by Evöolution Aerospace, Inc.

First Aviation Services Inc.®



Setting the HIGHEST STANDARDSM



FAA, EASA & other foreign civil aviation maintenance approvals

Over 120 DOD source approvals

Six Maintenance, Repair & Overhaul facilities:

1. Anderson, CA
2. Dallas/Addison, TX
3. Ft. Lauderdale, FL
4. Kissimmee, FL
5. Wichita, KS
6. Winston-Salem, NC

Four Production & Manufacturing facilities:

1. Ft. Lauderdale, FL
2. Kissimmee, FL
3. Wichita, KS
4. Winston-Salem, NC

AS9110C & AS9100D certified

275 Employees: qualifies as a Small Business for Government Contracts

OEM Licensed

Engineering Services:

- » Parts Manufacturing Approval (PMA)
- » Designated Engineering Representative (DER) repairs
- » Supplemental Type Certificates (STC)
- » Department of Defense Source Approvals (SAR)
- » Diminishing Manufacturing Sources & Materiel Shortages (DMSMS) solutions

REPAIR & OVERHAUL SERVICES

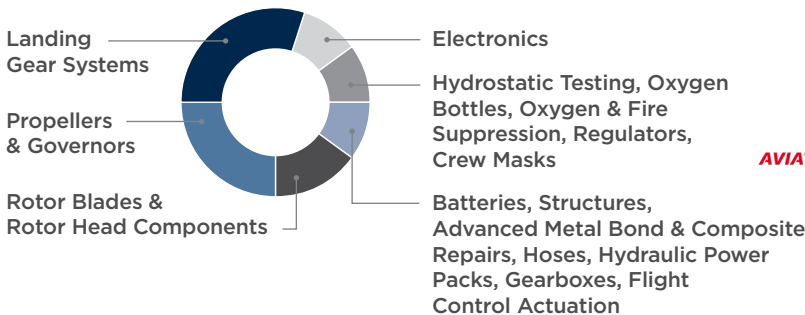

First Aviation Services Inc.®

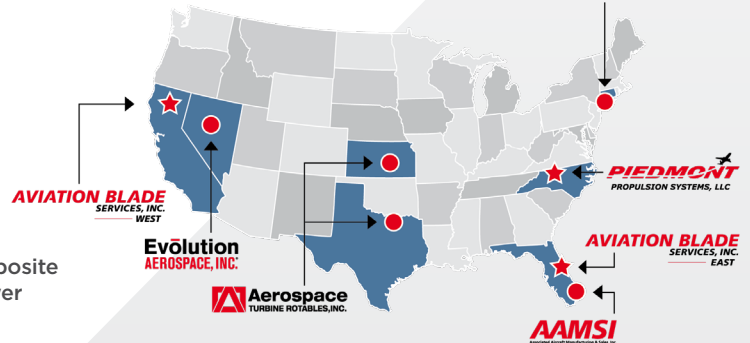

FAVS CUSTOMER BASE



Corporate & General Aviation

Airline

Military & Government

AIRLINE



MILITARY & GOVERNMENT



CORPORATE & GENERAL AVIATION



First Aviation Services Inc.®

PRODUCT TYPES

Advanced Metal Repairs/Arc Spray
Batteries
Beacons

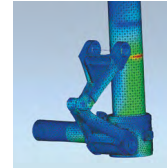

Lighting Units
Motors
Shimmy Dampers
Navigation Lights
Oxygen Bottles
Oxygen Masks
Oxygen Regulators & Valves
Pneumatic Reservoirs

Blow Down Bottles
Brakes
Circuit Cards
Composite Bottles
Composite Repair



Electro-mechanical Actuators
Electronics
Fire Bottles
Fire Extinguishers
Flight Control Actuators
Flight Control Surfaces



Power Supplies
Propellers
Rotor Blades
Propeller Blades
Overspeed Governors
Rotor Hubs



Gearboxes
Hydraulic Actuators
Hydrostatic Testing
IFF Systems
Prestolite Power Packs
Landing Gear
PMA Parts
Landing Lights



Propeller Hubs
Strobe Lights
Tach Generators
Tail Hooks
Transponders
Voltage Regulators
Wheels
Wire Harness Assemblies



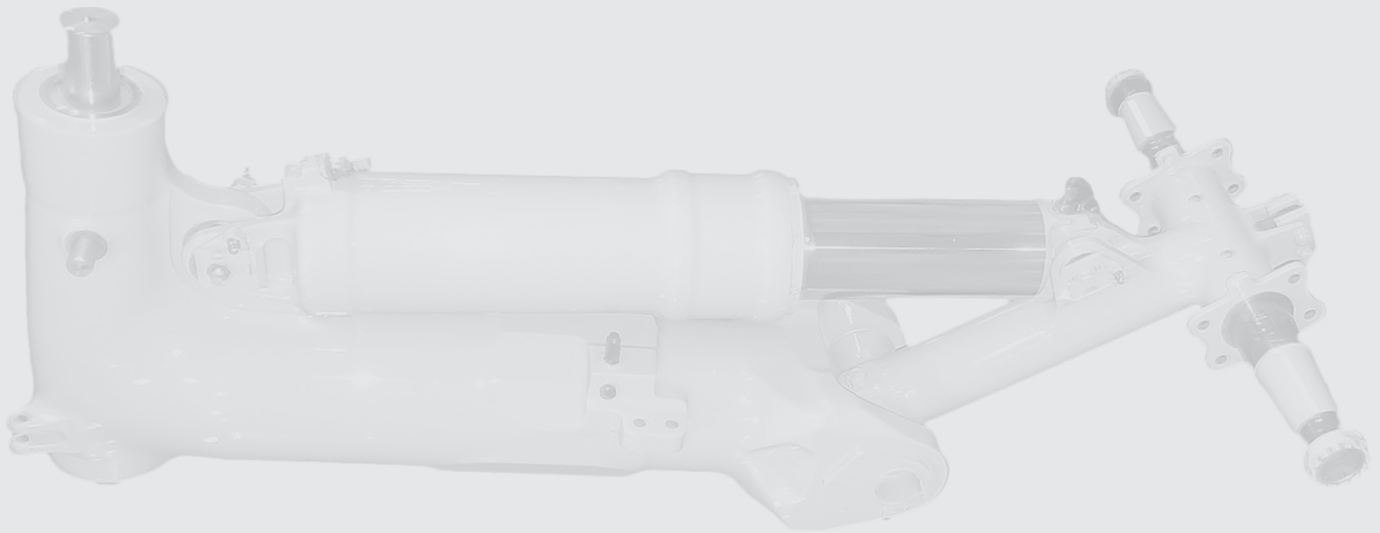

Aerospace
TURBINE ROTABLES, INC.



Product Line by Aerospace Turbine Rotables, Inc.



Landing Gear

When an operator turns to **AEROSPACE TURBINE ROTABLES, INC.** for their landing gear maintenance, they not only save on the cost of the landing gear component, but avail themselves of an exponentially larger number of competent airframe MRO facilities – saving money, time and convenience.

AeTR understands the urgency associated with returning aircraft to service.

We recognize that even when requirements are associated with scheduled maintenance, timely delivery of high quality components is the only acceptable solution. AeTR has a robust portfolio of capabilities and cost effective solutions to support landing gear system requirements.

- **FAA Certified** to overhaul landing gear systems and related components for nearly 50 years
- Capabilities include **mechanical, electromechanical, and hydraulic components**
- Has a history of providing overhaul services for **more than 51,000 articles**
- Annually provides MRO services for **more than 1,200 landing gear assemblies and associated system components**



LEAR · CHALLENGER · GLOBAL · PHENOM · GULFSTREAM · KING AIR





AeTR has an unwavering focus on high quality customer solutions.



AeTR has committed significant investment to solutions which increase MRO velocity and customer options.

- **Pool Stock programs** bring options and high velocity solutions to the MRO cycle
- **Exchange component inventory** brings immediate solutions to urgent requirements
- **Embedded engineering support** enables rapid development of tooling, specialized repairs, and replacement parts



LANDING GEAR



AeTR has an unwavering focus on high quality customer solutions.

- **MRO cycle velocity**
- **Improvement in product reliability**
- **Development of solutions** which provide customers with expanding options
- **Reduction in customer cost** of operations/total cost of ownership



Landing Gear (continued)



DRAG LEGS / SIDE STAYS

AeTR maintains a robust pool of drag stays/side stays which complements our customer overhaul activity. We manage complete assemblies which are sold through our exchange programs, as well as the individual castings, links, arms, and braces which have undergone the reconditioning process and are available for immediate use.

The sub-assembly components which are not uniquely serialized can be ingested immediately into overhauls which enables AeTR to move into the assembly process immediately upon completion of the fits, tolerance check, and NDI. This strategy cuts days from the typical MRO cycle on this family of components.

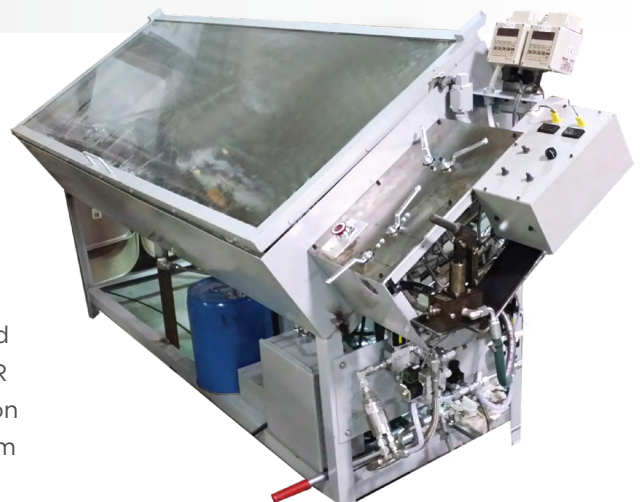



WHEELS & BRAKES

AeTR has extensive experience in providing MRO services for aircraft wheels and brakes. Our wheel shop can provide many levels of MRO service:

- Tire Change Inspection
- Wheel Repair
- Wheel Overhaul
- Non-destructive Inspection (Mag Particle, Fluid Penetrant, & EddyCurrent)

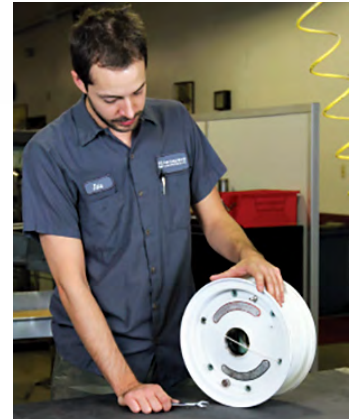

BRAKE OVERHAUL

The range of our wheel and brake programs extends across almost all airframes.

WHEELS:

- Cleveland
- Honeywell (Bendix)
- MABS (ABS & Dunlop)
- Goodrich
- Jay Em
- Messier

BRAKES:

- Cleveland
- Honeywell (Bendix)
- MABS (ABS & Dunlop)
- Goodrich
- Jay Em

AIRFRAMES:

- Aero Commander
- Boeing
- Cessna
- Embraer
- Lockheed
- Pilatus
- Sabreliner
- ATR
- Bombardier
- Dassault Falcon
- Fairchild
- Mitsubishi
- Piper
- Short
- Beechcraft
- British Aerospace
- DeHavilland
- Gulfstream
- Piaggio
- Saab
- Sikorsky





Hydraulics



HYDRAULIC ACTUATORS



AeTR currently repairs and overhauls a wide range of hydraulic actuators. Retract actuators, door actuators, uplock/downlock actuators, all fit well into our capabilities. AeTR has test stands for both red fluid and Skydrol actuator types and has engineered many solutions relevant to this product line.

FLUTTER DAMPER

AeTR provides detail inspection, repair, and overhaul services for many hydraulic dampers, including the flutter dampers used on Bombardier’s Challenger family. Our specialized test equipment enables us to service, troubleshoot, repair, test, and overhaul flutter dampers in accordance with the published maintenance requirements.

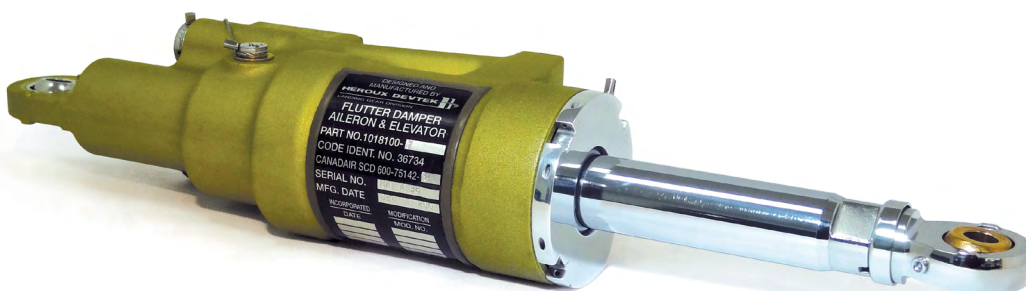

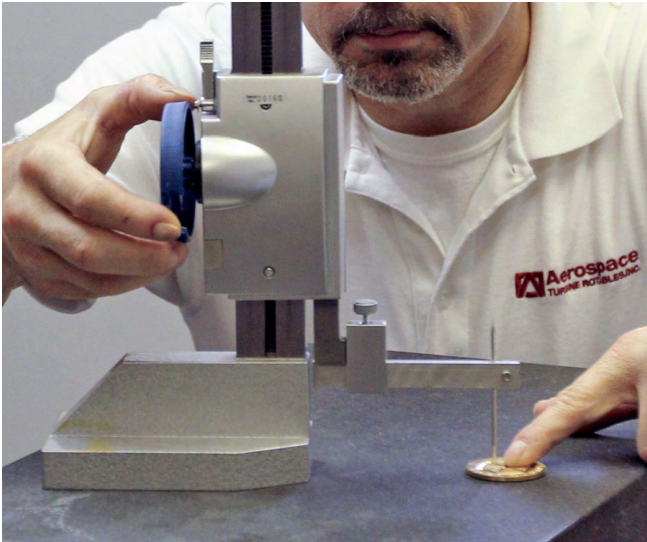

MASTER CYLINDERS

AeTR overhauls many types of master cylinders. Our services provide high value solutions to the requirements of both scheduled and unscheduled maintenance events involving brake systems.



SHIMMY DAMPERS

AeTR has overhaul capabilities on a number of aircraft shimmy dampers. Our shop has provided MRO services on thousands of shimmy dampers of many types. We have developed replacement part solutions for common high cost replacement items, and have active engineering projects focused on this product line.

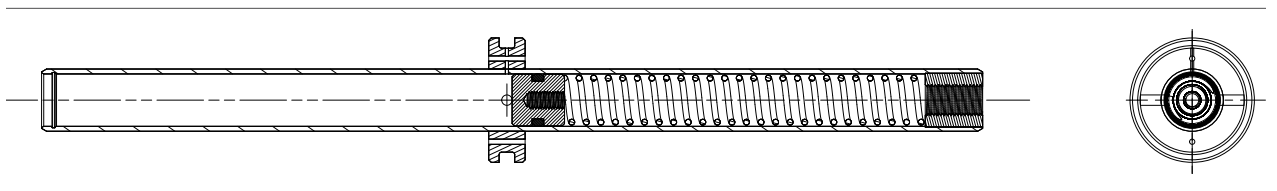

HYDRAULICS



Mechanical & Electro-Mechanical



KING AIR SPECIALISTS

FLAP ACTUATORS

AeTR's flap actuator shop specializes in the Beechcraft family of mechanical actuators, but also works on a variety of others. AeTR's robust engineering capabilities have developed a product line which is very efficient and cost effective for the operator to maintain.



TRIM TAB ACTUATORS



AeTR works on control surface trim actuators of many types and origins. Our trim actuator shop specializes in mechanical actuators which are gear, chain, or cable driven. Many repairs and repair parts have been developed by AeTR in order to mitigate the cost and delays commonly associated with new part replacement on the mechanical trim actuators used on aging airframes.



LANDING GEAR RETRACT ACTUATORS

AeTR has worked diligently to develop MRO programs for Mechanical Landing Gear Actuators. Currently, AeTR holds more than 25 replacement part approvals associated with the Beechcraft retract actuator line. AeTR's efforts on this product line have resulted in increased reliability and reduced cost for this actuator, and have transformed customer expectations in the marketplace. This program embodies solutions which are easily transferrable to other similar component programs.

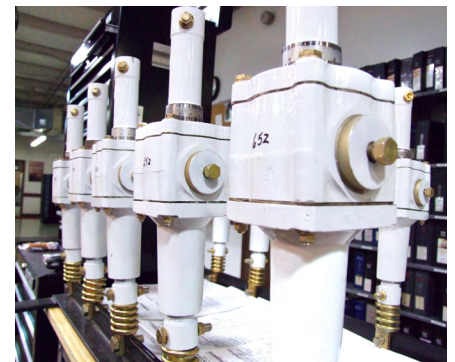
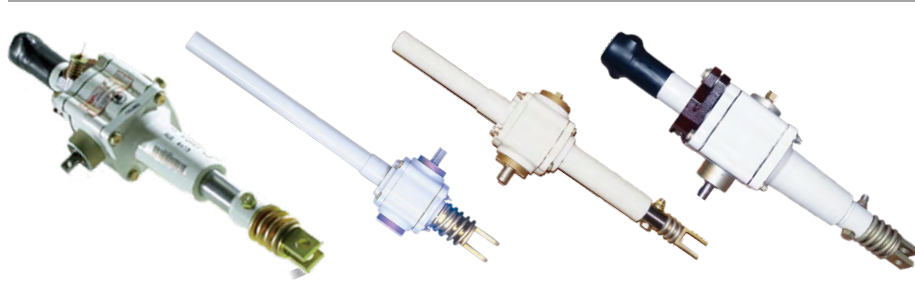

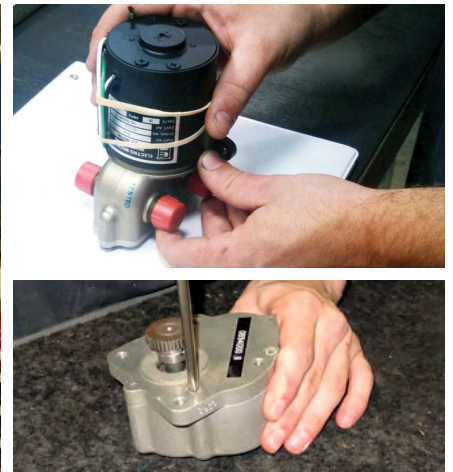

LANDING GEAR MOTORS & GEARBOXES

AeTR holds impressive market share on the products for which we provide MRO services and performs as sub-contractor to many shops with whom we previously competed for this product line.

Our overhauls embody a level of craftsmanship unchallenged in the industry. We have engineered and gained FAA approval on a host of solutions for this product line to enhance product quality/longevity, while reducing/containing costs.

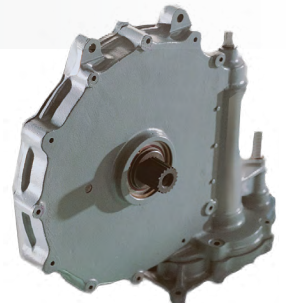

FLAP MOTORS & GEARBOXES

AeTR's Flap Motor and Gearbox shop has a wide range of capabilities. Our products are recognized as industry leading quality by operators world wide. As with our other product lines, the Flap Motor and Gearbox shop has developed specialized solutions which enhance the product quality and longevity while enabling operators to manage their maintenance costs more effectively.



MECHANICAL



Prestolite Power Packs

POWER PACKS

AeTR as the OEM for Prestolite Powerpacks for aviation has more experience than anyone in the repair and overhaul of Prestolite Powerpacks. At AeTR we go through an extensive overhaul process that includes the replacement of the motor, valves, springs, gaskets, O-rings, pressure adjusting screws, and eyelets with brand new components. Each overhauled powerpack is subjected to stress tests prior to shipment including cycling the powerpack far beyond what would be experienced in typical field operation. AeTR now installs thermal switches to prevent overheating of the motor for further protection and has developed new castings for the valve body with modern manufacturing techniques.

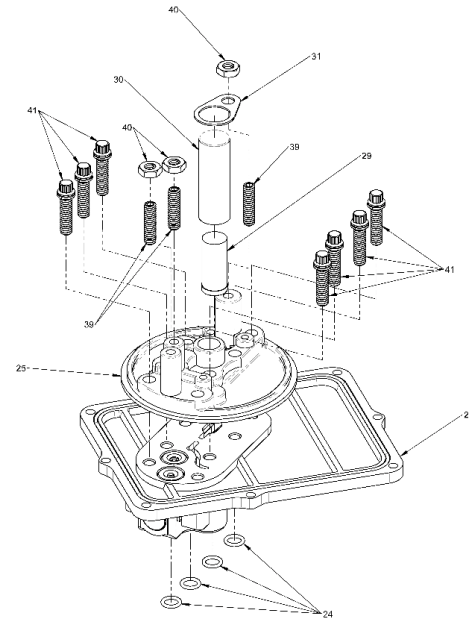
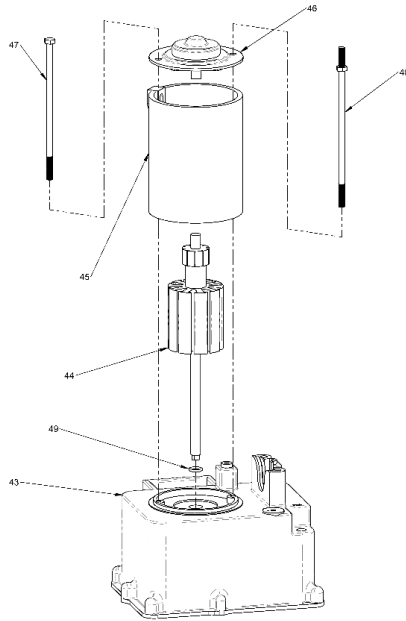
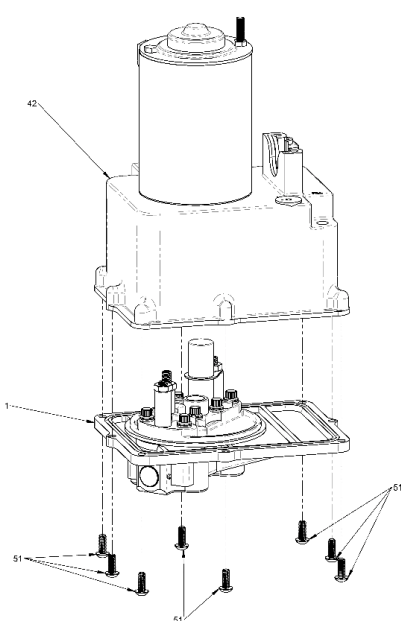
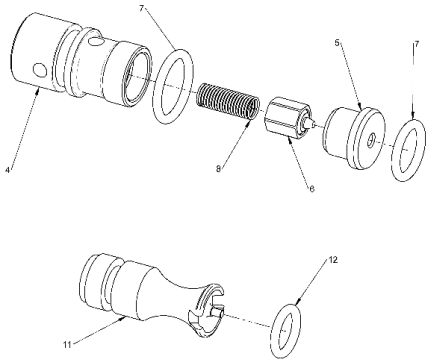



Hydrostatic & Safety Equipment

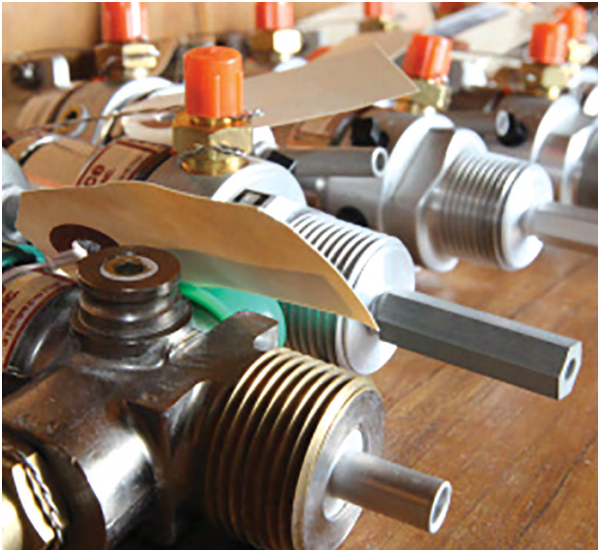

At AeTR, our safety equipment shop sets the industry standard for turnaround time. Because our hydrostatic services are embedded into our FAA/EASA approved repair station, AeTR provides a complete documentation package inclusive of DOT/FAA/EASA certification. Our range of products is robust with capabilities for Oxygen Cylinders, Nitrogen Cylinders, Fire Extinguisher Cylinders, Regulators, Valves, Shut-off Valves, and Crew Oxygen Masks. AeTR has provided MRO services on more than 102,000 safety equipment articles over the past 20 years.

WE RECYCLE HALON





Hydrostatic & Safety Equipment: Oxygen Cylinders

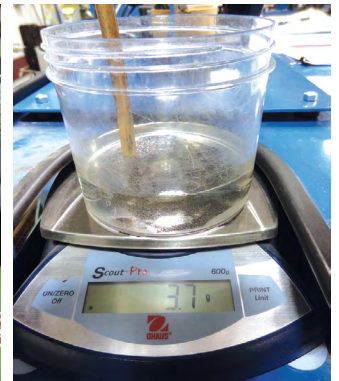

OXYGEN CYLINDERS

AeTR has held DOT certification for the requalification of pressure cylinders for more than 25 years. Our shop is well positioned for high volume throughput with three test jackets, three test stands, multiple bottle dryers, a bottle tumbler, and numerous fixtures to support a high volume of work. Collaborative partnerships allow us to provide replacement bottles when required, enabling our customers to turn to us with confidence; knowing we will provide effective and expedient solutions.



Hydrostatic & Safety Equipment: Fire Bottles

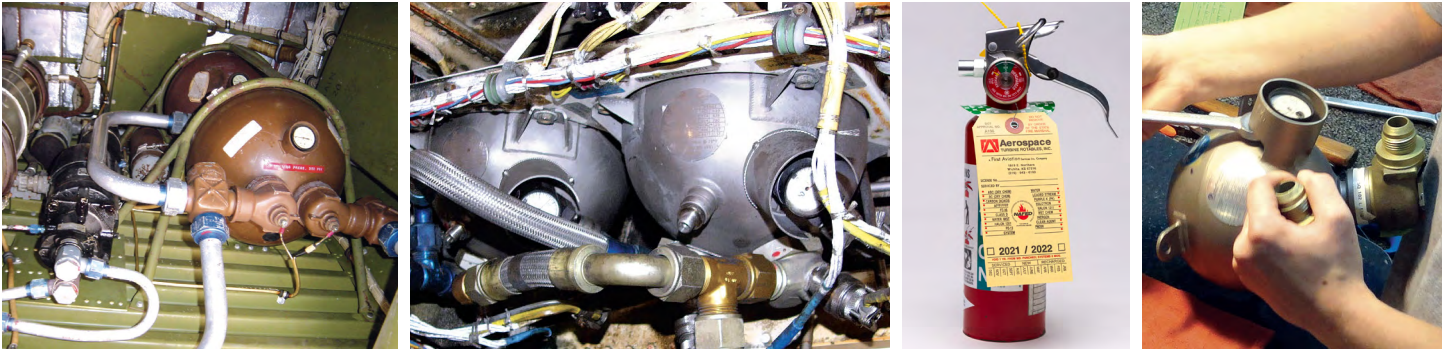

FIRE EXTINGUISHERS

AeTR is a prominent provider of aerospace engine/apu fire bottle overhaul. AeTR has invested in

the necessary equipment and has

developed the qualified staff, product knowledge, and experience to provide excellent service

supporting this product line. AeTR provides overhaul services for both screw-thread and hermetically

sealed engine fire extinguishers. Halon recovery and recycling equipment is included in our tools and

fixtures, allowing us to provide regulatory compliant, environmentally friendly, and cost effective service

in support of halon fire extinguishing systems. Our solutions are constantly focused on customer

requirements and customer expectations. Through that focus, AeTR has become one of the most versatile

and capable independent engine fire extinguisher shops in the world.



BLOW-DOWN BOTTLES

AeTR provides requalification services for cylinders and overhaul services for valves on

a wide range of emergency reservoirs. Our

technical data library is extensive, as are our

capabilities. Our ever-expanding capabilities

include reservoirs manufactured by:

- HTL
- Tavco
- Sota
- Globe
- Pacific-Scientific
- Futurecraft
- Southbend Controls





Hydrostatic & Safety Equipment: Oxygen Masks & Regulators



OXYGEN MASKS

AeTR has recently launched an oxygen mask overhaul program. We have developed our own tooling and test fixtures with the versatility to expand our capabilities quickly without significant investments or the lengthy lead times associated with OEM uniquely specialized equipment. Our efforts are now focused on bringing velocity and cost relief to another product line which has proven to be difficult for our customers.

Our current capabilities include quick-donning crew masks manufactured by:

- **BE Aerospace**
- **Scott/Avox**
- **Intertechniques**



OXYGEN SHUT-OFF VALVES

AeTR can provide overhaul of most mechanical oxygen shut off valves.
 These valves are overhauled in accordance with approved data and returned to service with FAA/EASA airworthiness forms.

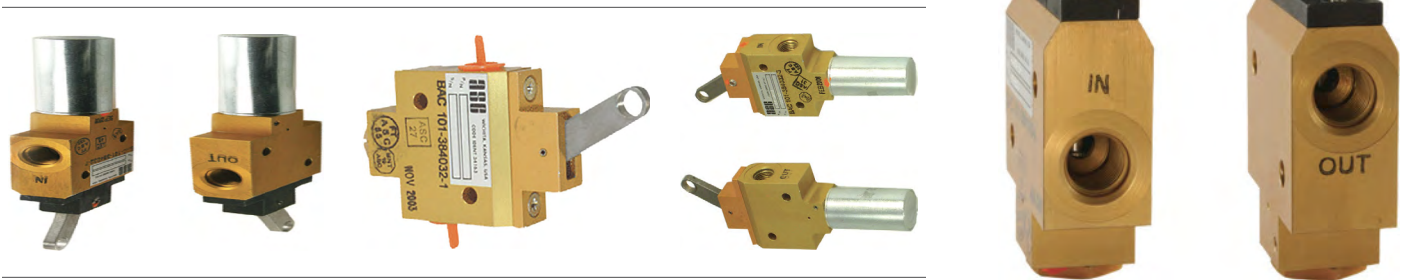

OXYGEN VALVES / REGULATORS

AeTR has developed in-house overhaul capabilities for oxygen valves and regulators sent to us for requalification. Our in-house valve overhaul solution enables AeTR to consistently meet and exceed demanding customer expectations consistently. AeTR is constantly developing new capabilities, new test equipment, and new solutions for this product line.



HYDRO & SAFETY



Electronics



STROBE POWER SUPPLIES

- Grimes
- Whelan
- SDI

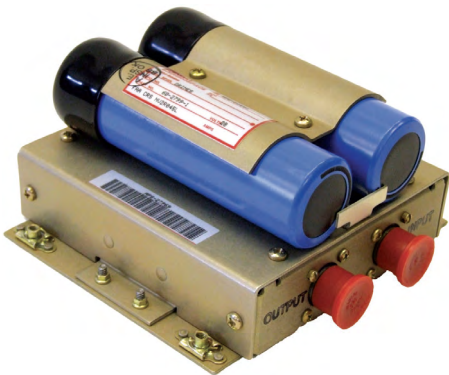

RETRACTABLE LANDING LIGHTS

AeTR has a special niche in this market. Our repair parts developmental efforts have returned great dividends to this product line. AeTR has specialized in retractable landing lights and helicopter search lights for more than two decades. Our solutions for replacement gears, actuators, switches, and motors has resulted in impressive reliability improvements and reduced cost of operations for many operators of these aged electromechanical lights.



STROBE LIGHTS

- Grimes
- Whelan
- SDI





ROTATING BEACONS

AeTR has developed a specialized expertise in the repair of rotating/oscillating beacons. These mechanical lighting products have a number of internal wear components for which AeTR has developed cost effective solutions. The cost of replacement/repair parts associated with this family of products escalated significantly as new technologies began to displace the mechanical rotating/oscillating beacon. Our solutions have enabled these products to continue in service, and perform years beyond their expected design life.

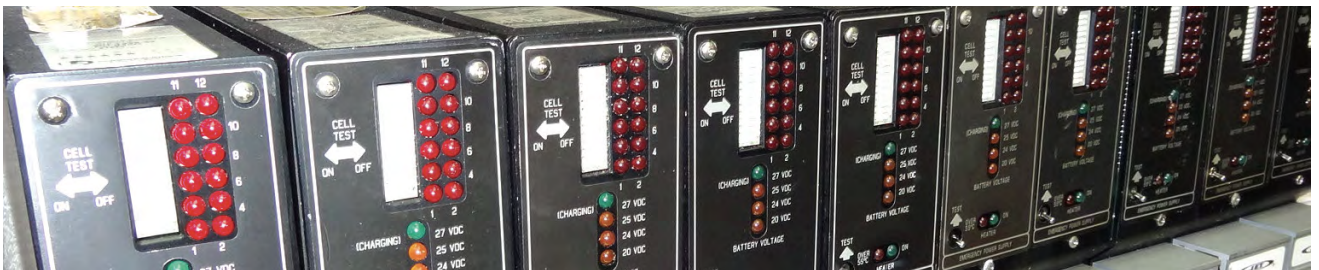

EMERGENCY POWER SUPPLIES & BATTERIES

AeTR has been repairing and servicing emergency power supplies and batteries for many years. As we expand our selection of specialized harnesses, test boxes, and troubleshooting equipment; we continue to grow our market share in this product line. Unlike many shops which do an initial functional test and then replace the battery pack, AeTR does a full evaluation and replaces batteries and/or controllers only when necessary. Our repair to reconditioning ratio remains well below comparable shop averages. At AeTR we understand the balance of time and money and recognize that troubleshooting by replacing parts can be an expensive solution for our customers.



ELECTRONICS



Structures



METAL BOND

AeTR's Metal Bond Department focuses on the repair of metallic bonded honeycomb structures. Control surfaces, cowlings, engine inlets, thrust reversers, exhaust nozzles, landing gear doors, and nacelle doors are products which are processed by our Metal Bond Repair Team. Our shop provides metal bond solutions for aluminum, titanium, and stainless steel. When articles require repair which is beyond what is authorized in the airframe maintenance or structural repair manual, AeTR's Structures Team works with the AeTR Engineering Department to develop and approve the required repair specification. Our structures group is well equipped with experienced technicians, robust technical data libraries, and processing/finishing equipment which enables us to produce high velocity, high quality results.

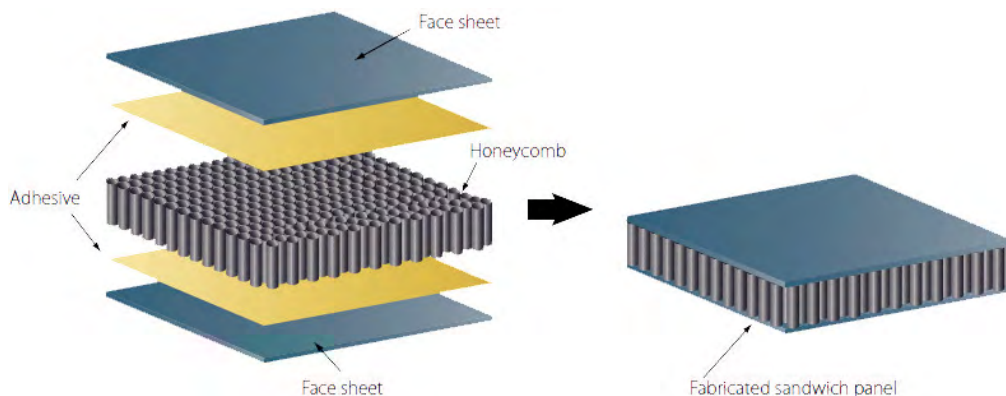

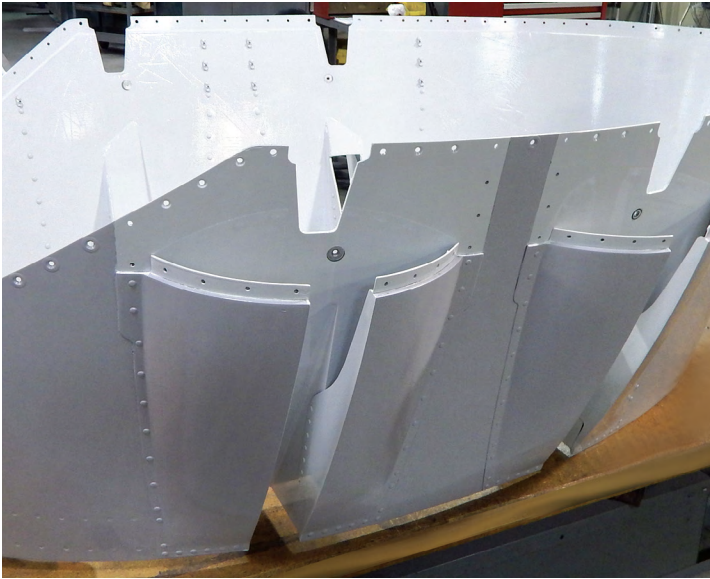

ADVANCED COMPOSITE REPAIR

AeTR's Advanced Composite Repair Department is focused on the repair of composite bonded honey-comb structures. Control surfaces, engine inlets, thrust reversers, landing gear doors, radomes, fairings, various airframe panels, and nacelle doors are products which are processed by our Advanced Composites Repair Team. Our shop provides advanced composite repair solutions for fiberglass, kevlar, carbon fiber, and aramid articles. The AeTR team has extensive experience with composite defects such as punctures, cracks and disbond, and is well equipped with the knowledge and experience required to transform damaged articles to airworthy. When articles require repairs which are not approved in the airframe maintenance or structural repair manual, AeTR's Structures Team works directly with the AeTR Engineering Department to develop and approve the required repair specification. Our structures group is well equipped with experienced technicians, robust technical data libraries, and processing/finishing equipment which enables us to produce high velocity, high quality results.





Engineering

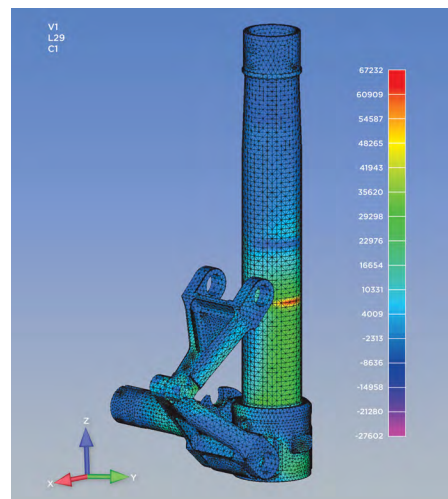

AeTR holds all of the required delegations, certifications, and approvals from the FAA to design, develop, certify, and manufacture engineered solutions. First Aviation employs a RS-DER capable of reviewing and approving major repairs, alterations, and repair processes in conjunction with the local FAA. The RS-DER delegation is extremely rare, allowing FAVS to write and approve Component Overhaul Manuals on behalf of the FAA / FSDO Flight Standards District Office (FSDO).

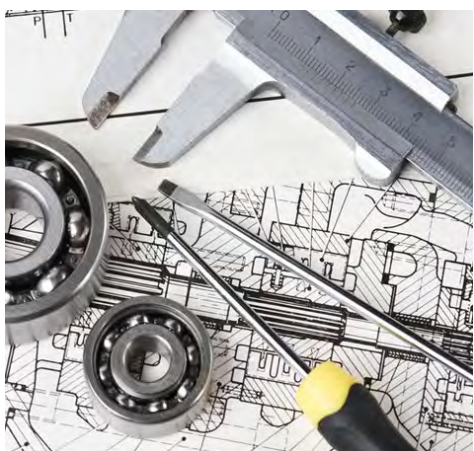
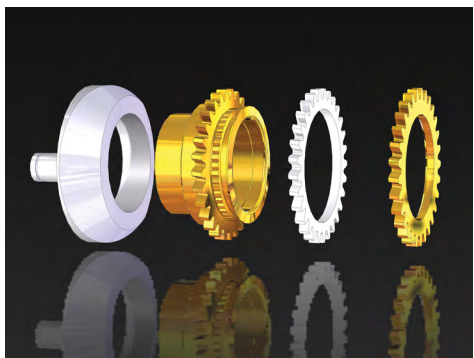

AeTR is an FAA-certified Production Approval Holder (PAH). As such, AeTR can control the design, manufacture, supply chain, and quality of parts produced using Parts Manufacturer Approval (PMA) authorization from the FAA. AeTR, acting under the authority of its PAH certification, certifies, audits, and manages a large pool of qualified vendors in order to ensure high quality, short lead times, and competitive costs.

AeTR also employs FAA Designated Manufacturing Inspection Representatives (DMIR) who, on behalf of the FAA, inspect and certify that the products AeTR uses are produced in accordance with an appropriate FAA certification. First Aviation has identified, designed, developed, certified, and produced the following DMSMS engineered solutions:

- **Over 200 Parts Manufacturing Approvals (PMA)**
- **Over 50 FAA-approved Repair Processes**
- **Supplemental Type Certificates (STC)**
- **Service Life Extension Program (SLEP)**
- **FAA-approved Component Overhaul Manuals**

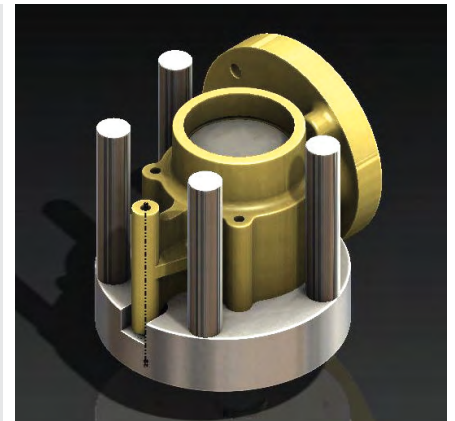
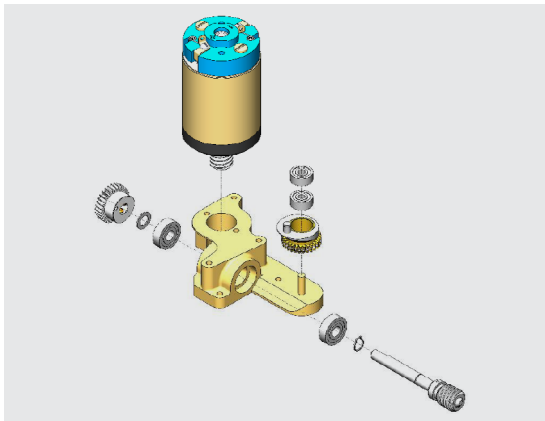
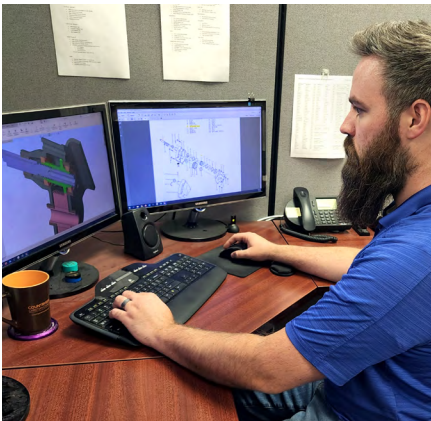

AeTR's understanding of corporate aircraft landing gear systems also results in several options to minimize the system's total life cycle cost. AeTR can both extend service life and prevent common Beyond Economical Repair (BER) situations that would otherwise result in an expensive replacement. AeTR holds several proprietary FAA-approved repair processes that can not only extend the life of a component but save money by eliminating the need to purchase new parts for BER replacement.

AeTR engineers have developed the following types of value-added engineered solutions:

Alternative / Replacement Parts

Design and produce a part to directly replace a material due to reliability issues, DMSMS issues, high cost, or lead time

Repair Scheme

Develop and certify a repair scheme, including the required technical data and/or maintenance manuals, to repair serviceable material in order to avoid scrap / replacement or to extend time on wing

Service Life Extension Program (SLEP)

Develop and certify a modification to extend the life limit of an aircraft component; these engineered solutions are then certificated through the US Federal Aviation Administration (FAA)

Parts Manufacturing Authority (PMA)

PMA is a FAA approval for the combined design and production of a replacement / alternate part

Supplemental Type Certificate (STC)

STC is a certification document issued by the FAA approving a modification to an aircraft, engine, or propeller

FAA-approved Major Repairs or Alterations via a Designated Engineering Representative (DER & RS-DER)

- A DER is a delegate of the FAA administrator, who can review and recommend approval of major repairs or alterations to aircraft and components
- A RS-DER is a DER who can also approve Repair Processes (including Maintenance Manuals) to allow multiple uses of a developed repair scheme or alteration



Stratoflex Hoses

AeTR is one of a small number of companies who operate a Stratoflex Authorized Distributor Hose Shop. Our Stratoflex distributorship allows us direct access to the Stratoflex technical library and the drawings, blueprints, and specifications therein; as well as providing us with distributor level pricing for hose manufacturing materials and couplings. Our hose shop, much like our other product lines, is recognized for fast delivery and exceptional quality. Our hose shop team can typically manufacture hoses and ship them the day after receipt of order. We also manufacture a number of hose kits, many to customer specification. The hose kitting process allows our customers to manage standard replacement hoses under a single part number, thus reducing the administrative cost and burden associated with long lists of hoses which are frequently ordered. We have the ability to cross reference most OEM part numbers and are able to mark the hose identification tag with both the OEM and Stratoflex part numbers when requested.



Visit our **NEW** "Build-a-Hose" Shop!



Aerospace
TURBINE ROTABLES, INC.
First Aviation Services Inc.*

BUILD A HOSE

SHOPPING CART(0)
\$0.00

REQUEST A QUOTE

CHOOSE OPTIONS TO SHOW IMAGE

HOSE TYPE *
Select Hose Type

SIZE *
Select Size

FITTING 1 * Select Fitting 1 **FITTING 2 *** Select Fitting 2

SLEEVE
Select Sleeve

LENGTH (IN INCHES) *
Enter desired length

EMAIL *
Email

FULL NAME *
Full Name

PHONE
Phone

I'm not a robot reCAPTCHA
Privacy - Terms

SUBMIT REQUEST



Program Management



SUPPLY CHAIN AND INVENTORY MANAGEMENT

AeTR utilizes its depth of engineering and MRO experience to provide creative solutions to Supply Chain Management. Whether you're transitioning to a new commercial fleet or managing a legacy military platform, AeTR has the resources to work with you to control and reduce direct operating costs. **In addition to performing MRO tasks, AeTR invests in a large inventory of repaired parts, consumables, expendables, pool stock, and exchange stock to support your program.** We focus on optimal product availability at either the customer's site or designated distribution centers. Our customers report that our strategic solutions reduce the complexity and administrative burden of the purchase order cycle, as well as the length of the stock replenishment cycle.



FAA-PMA Parts by Evöolution Aerospace

Evöolution
AEROSPACE, INC.®



Evöolution Aerospace, Inc. understands the prohibitively high cost of maintaining legacy airframe systems. We've developed an extensive, high quality line of alternative parts for your requirements: from motors to capacitors, bearings to bushings — we have dozens of cost effective, high quality, FAA approved replacement components.





EXPERIENCE YOU CAN RELY ON.

With nearly 50 years of experience, Aerospace Turbine Rotables has earned a reputation across the industry for “Excellence of Products” and “Excellence of Service.” Our values have remained consistently focused on the quality of our components, our ability to deliver in accordance with customer commitments, and our prevailing attitude of customer satisfaction. Today our company and its employees are more committed than ever to the pursuit of excellence in the products and services we provide.

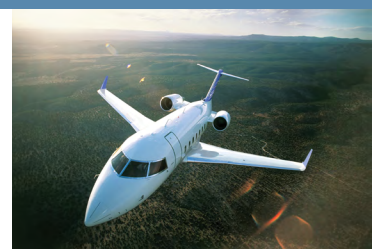

Experience why thousands of our customers from all over the world have made us their supplier of choice. **Contact Sales at 316.943.6100 or sales@turbinerotables.com today!**

Repair Station Certifications

CAGE CODE: 4PEE3

FAA Repair Station NV2R045L (Wichita, KS)

FAA Repair Station IGTR154L (Addison, TX)

EASA 145.4033